

4000 Series 4008TAG2A Diesel Engine – Electropak

947 kWm @ 1500 rpm

The Perkins 4000 Series family of 6, 8, 12 and 16 cylinder diesel engines was designed in advance of today's uncompromising demands within the power generation industry and includes superior performance and reliability.

The 4008TAG1A/2A Electropaks are turbo-charged, air-to-air charge cooled, 8 cylinder in-line diesel engines. Offered with either Temperate or Tropical cooling packages (with or without fuel cooling). Their premium design and specification features provide economic and durable operation as well as exceptional power to weight ratio, improved serviceability, low gaseous emissions, overall performance and reliability essential to the power generation market.

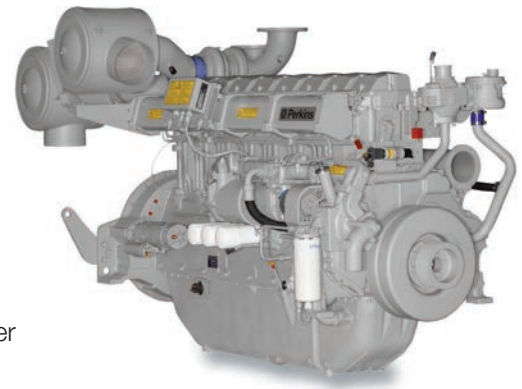

Specification			
Number of cylinders	8 vertical in-line		
Bore and stroke	160 x 190 mm	6.3 x 7.5 in	
Displacement	30.561 litres	1865 in ³	
Aspiration	Turbocharged and air-to-air charge cooled		
Cycle	4 stroke		
Combustion system	Direct injection		
Compression ratio	13.6:1		
Rotation	Anti-clockwise, viewed from flywheel end		
Total lubricating capacity	153 litres	40.4 US gal	
Cooling system	Water-cooled		
	Temperate cooling		Tropical cooling
Total coolant capacity	143 litres	37.8 US gal	149 litres 39.4 US gal

www.perkins.com

Photographs are for illustrative purposes only and may not reflect final specification. All information in this document is substantially correct at time of printing and may be altered subsequently. Final weight and dimensions will depend on completed specification.

Publication No. PN1832B/12/14 Produced in England ©2014 Perkins Engines Company Limited

 **Perkins**[®]

THE HEART OF EVERY GREAT MACHINE

4000 Series 4008TAG2A Diesel Engine – ElectropaK

947 kWm @ 1500 rpm

Features and benefits

Economic power

- Individual four valve per cylinder heads give optimised gas flows, whilst digitally governed unit fuel injectors ensure ultra fine fuel atomisation and hence controlled rapid combustion, for efficiency and economy
- Commonality of components with other engines in the 4000 Series family allows reduced parts stocking levels

Reliable power

- Developed and tested using latest engineering techniques
- Piston temperatures are controlled by an advanced gallery jet cooling system
- All engines are tolerant of a wide range of temperatures without derate
- Perkins global product support is designed to enhance the customer experience of owning a Perkins powered machine. We deliver this through the quality of our distribution network, extensive global coverage and a range of Perkins supported OEM partnership options. So whether you are an end-user or an equipment manufacturer our engine expertise is essential to your success

Clean, efficient power

- Exceptional power to weight ratio and compact size for easier transportation and installation
- New designed radiator assemblies with corrosion inhibiting powder coated surfaces; fewer pipe joints and easier access to reduce maintenance times
- Designed to provide excellent service access for ease of maintenance
- Engines designed to comply with major international standards
- Low gaseous emissions for cleaner operation

www.perkins.com

Photographs are for illustrative purposes only and may not reflect final specification.
All information in this document is substantially correct at time of printing and may be altered subsequently.
Final weight and dimensions will depend on completed specification.

Publication No. PN1832B/12/14 Produced in England ©2014 Perkins Engines Company Limited

 **Perkins**[®]

THE HEART OF EVERY GREAT MACHINE

4000 Series 4008TAG2A Diesel Engine – Electropak

947 kWm @ 1500 rpm

Technical information

Air inlet

- Mounted oil filters and turbochargers

Fuel system

- Unit fuel injectors with lift pump and hand stop control
- Digital electronic governor to ISO 3046 Part 4 Class A1
- Full-flow spin-on fuel oil filters

Lubrication system

- Wet sump with filler and dipstick
- Full-flow spin-on oil filters
- Engine jacket water/lub oil temperature stabiliser

Cooling system

- Gear driven circulating pump
- Twin thermostats
- Crankshaft pulley for fan drive
- Powder coated radiator assemblies comprising: water radiator; air charge cooled radiator; fuel oil cooling (optional); all pipes, hoses and clips; fan; pulley; fan belts and safety guards

Electrical system

- 24 volt starter motor and 24 volt/40 amp alternator with integral regulator and DC output
- 24 volt combined high coolant temperature/low oil pressure switch
- Overspeed switch and magnetic pickup
- Turbine inlet temperature shutdown switch
- 24 volt stop solenoid (energised to run)

Flywheel and housing

- Flywheel to SAE J620 size 18
- SAE 0 flywheel housing

Optional equipment

Other optional extra equipment available:

Choice of Temperate or Tropical radiators available dependent on operational cooling requirements

Fuel oil cooling radiator available integral to radiator assemblies

Twin heavy duty air cleaner – paper element with pre-cleaner

Changeover lubricating oil filter

Changeover fuel oil filter

Immersion heater with thermostat

Air starters

Instrument panel

Note: This list is not exhaustive, further options may be available to meet particular applications on enquiry to Perkins Sales Department

www.perkins.com

Photographs are for illustrative purposes only and may not reflect final specification.
All information in this document is substantially correct at time of printing and may be altered subsequently.
Final weight and dimensions will depend on completed specification.

Publication No. PN1832B/12/14 Produced in England ©2014 Perkins Engines Company Limited

 **Perkins**[®]

THE HEART OF EVERY GREAT MACHINE

4000 Series 4008TAG2A Diesel Engine – Electropak

947 kWm @ 1500 rpm

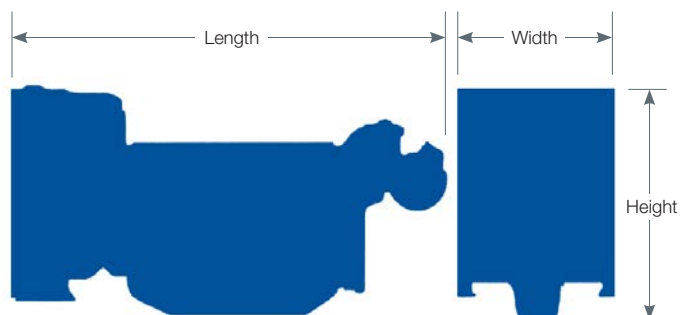

Engine package weights and dimensions				
	Temperate cooling		Tropical cooling	
Length	3852 mm	151.7 in	3711 mm	146 in
Width	2046 mm	80.5 in	2046 mm	80.5 in
Height	2067 mm	81.3 in	2146 mm	84.5 in
Weight (dry)	4270 kg*	9414 lb	4320 kg*	9524 lb

* For fuel cooler, add 6 kg

www.perkins.com

Photographs are for illustrative purposes only and may not reflect final specification. All information in this document is substantially correct at time of printing and may be altered subsequently. Final weight and dimensions will depend on completed specification.

Publication No. PN1832B/12/14 Produced in England ©2014 Perkins Engines Company Limited

 **Perkins**[®]

THE HEART OF EVERY GREAT MACHINE

4000 Series 4008TAG2A Diesel Engine – Electropak

947 kWm @ 1500 rpm

Speed rpm Radiator type	Type of operation	Typical generator output (Net)		Engine power			
				Gross		Net	
		kVA	kWe	kWm	bhp	kWm	bhp
1500 Tropical	Baseload power	809	647	719	964	681	913
	Prime power	1022	818	899	1206	861	1155
	Standby (maximum)	1125	900	985	1321	947	1270

The above ratings represent the engine performance capabilities guaranteed within plus or minus 3% at the reference conditions equivalent to those specified in ISO 8528/1, ISO 3046/1, BS5514/1.

Rating conditions: 25°C air inlet temperature, barometric pressure 100 kPa, relative humidity 30%. Please consult your distributor or the factory for ratings in other ambient conditions. **Note:** For full ratings please refer to Perkins Engines Company Limited. All electrical ratings are based on an average alternator efficiency and a power factor of 0.8. **Full specification:** BS2869: Class A1 + A2 or ASTM D975 No 2D.

Rating definitions

Baseload power: Power available for continuous full load operation. No overload is permitted. **Prime power:** Power available for variable load with an average load factor not exceeding 80% of the prime power rating in any 24 hour period. Overload of 10% permitted for one hour in every twelve hours operation. **Standby (maximum):** Power available at variable load in the event of a main power network failure up to a maximum of 500 hours per year. No overload is permitted.

Percent of prime power	Fuel consumption for temperate and tropical at 1500 rpm	
	g/kWh	l/hr
Standby (maximum)	209	240
Prime power	206	215
Continuous baseload power	206	172
75%	206	162
50%	207	111

4000 Series 4008TAG2 Diesel Engine – Electro Unit

924 kWm @ 1800 rpm

The Perkins 4000 Series family of 6, 8, 12 and 16 cylinder diesel engines was designed in advance of today's uncompromising demands within the power generation industry and includes superior performance and reliability.

The 4008TAG2 is a turbocharged, air-to-air charge cooled, 8 cylinder in-line diesel engine. Its premium design and specification features provide economic and durable operation as well as exceptional power to weight ratio, improved serviceability, low gaseous emissions, overall performance and reliability essential to the power generation market.

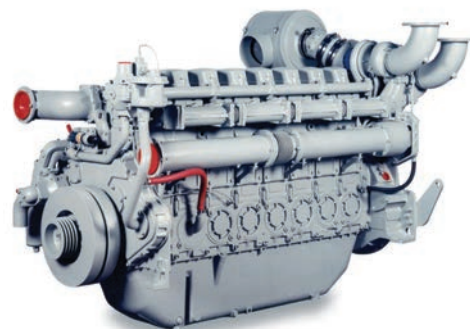

Specification				
Number of cylinders	8 vertical in-line			
Bore and stroke	160 x 190 mm	6.3 x 7.5 in		
Displacement	30.561 litres	1865 in ³		
Aspiration	Turbocharged and air to air charge cooled			
Cycle	4 stroke			
Combustion system	Direct injection			
Compression ratio	13.6:1			
Rotation	Anti-clockwise, viewed from flywheel end			
Total lubricating capacity	165.6 litres	43.7 US gal		
Cooling system	Water-cooled			
	Electro unit		ElectropaK	
Total coolant capacity	48 litres	12.7 US gal	162 litres	42.8 US gal

www.perkins.com

Photographs are for illustrative purposes only and may not reflect final specification.
All information in this document is substantially correct at time of printing and may be altered subsequently.
Final weight and dimensions will depend on completed specification.

Publication No. PN2199/12/14 Produced in England ©2014 Perkins Engines Company Limited

 **Perkins**[®]

THE HEART OF EVERY GREAT MACHINE

4000 Series 4008TAG2 Diesel Engine – Electro Unit

924 kWm @ 1800 rpm

Features and benefits

Economic power

- Individual four valve cylinder heads give optimised gas flows, while unit fuel injectors ensure ultra fine fuel atomisation and hence controlled rapid combustion, for efficiency and economy
- Commonality of components with other engines in 4000 Series family allows reduced parts stocking levels

Reliable power

- Developed and tested using latest engineering techniques
- Piston temperatures are controlled by an advanced gallery jet cooling system
- All engines are tolerant of a wide range of temperatures without derate
- Perkins global product support is designed to enhance the customer experience of owning a Perkins powered machine. We deliver this through the quality of our distribution network, extensive global coverage and a range of Perkins supported OEM partnership options. So whether you are an end-user or an equipment manufacturer our engine expertise is essential to your success

Clean, efficient power

- Exceptional power to weight ratio and compact size for easier transportation and installation
- Designed to provide excellent service access for ease of maintenance
- Engines designed to comply with major international standards
- Low gaseous emissions for cleaner operation

Product support

- Perkins actively pursues product support excellence by ensuring our distribution network invest in their territory – strengthening relationships and providing more value to you, our customer
- Through an experienced global network of distributors and dealers, fully trained engine experts deliver total service support around the clock, 365 days a year. They have a comprehensive suite of web based tools at their fingertips covering technical information, parts identification and ordering systems, all dedicated to maximising the productivity of your engine
- Throughout the entire life of a Perkins engine, we provide access to genuine OE specification parts and service. We give 100% reassurance that you receive the very best in terms of quality for lowest possible cost .. wherever your Perkins powered machine is operating in the world

www.perkins.com

Photographs are for illustrative purposes only and may not reflect final specification.
All information in this document is substantially correct at time of printing and may be altered subsequently.
Final weight and dimensions will depend on completed specification.

Publication No. PN2199/12/14 Produced in England ©2014 Perkins Engines Company Limited

 **Perkins**[®]

THE HEART OF EVERY GREAT MACHINE

4000 Series 4008TAG2 Diesel Engine – Electro Unit

924 kWm @ 1800 rpm

Technical information

Air inlet

- Mounted air filters and turbochargers

Fuel system

- Unit fuel injectors with lift pump and hand stop control
- Electronic governor to ISO 3046 Part 4 class A1
- Full-flow spin-on fuel oil filters

Lubrication system

- Wet sump with filler and dipstick
- Full-flow spin-on oil filters
- Engine jacket water/lub oil temperature stabiliser

Cooling system

- Gear driven circulating pump
- Twin thermostats
- Crankshaft pulley for fan drive
- Electrical Equipment
- 24 volt starter motor and 24 volt/40 amp alternator with integral regulator and DC output
- High coolant temperature switch
- Low oil pressure switch
- Overspeed switch and magnetic pickup
- Turbine inlet temperature shutdown switch
- 24 volt stop solenoid (energised to run)

Flywheel and housing

- Flywheel to SAE J620 size 18
- SAE 0 flywheel housing

Optional equipment

The following optional extra equipment is available to make up the specifications to the Perkins ElectropaK specification:

Tropical radiator including: water pipes, clips and hoses, fan, fan guards and belts

Other optional extra equipment available:

Twin heavy duty air cleaner – paper element with pre-cleaner

Changeover lubricating oil filter

Changeover fuel oil filter

Immersion heater with thermostat

Water pipes, clips and hoses for radiator

Air starters

Instrument panel

Note: This list is not exhaustive, further options may be available to meet particular applications on enquiry to Perkins Sales Department.

www.perkins.com

Photographs are for illustrative purposes only and may not reflect final specification.
All information in this document is substantially correct at time of printing and may be altered subsequently.
Final weight and dimensions will depend on completed specification.

Publication No. PN2199/12/14 Produced in England ©2014 Perkins Engines Company Limited

 **Perkins**[®]

THE HEART OF EVERY GREAT MACHINE

4000 Series 4008TAG2 Diesel Engine – Electro Unit

924 kWm @ 1800 rpm

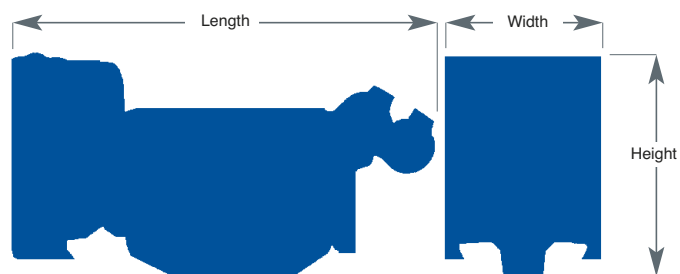

Engine package weights and dimensions

	Electro unit		ElectroPaK	
Length	2879 mm	113 in	3935 mm	155 in
Width	1571 mm	62 in	1870 mm	74 in
Height	1760 mm	69 in	2258 mm	89 in
Weight (dry)	3250 kg	7165 lb	4360 kg	9612 lb

www.perkins.com

Photographs are for illustrative purposes only and may not reflect final specification.
All information in this document is substantially correct at time of printing and may be altered subsequently.
Final weight and dimensions will depend on completed specification.

Publication No. PN2199/12/14 Produced in England ©2014 Perkins Engines Company Limited

 **Perkins**[®]

THE HEART OF EVERY GREAT MACHINE

4000 Series 4008TAG2 Diesel Engine – Electro Unit

924 kWm @ 1800 rpm

Speed rpm	Type of operation	Typical generator output (Net)		Engine power			
				Gross		Net	
		kVA	kWe	kWm	bhp	kWm	bhp
1800	Baseload power	783	626	715	959	659	885
	Prime power	995	796	894	1199	838	1124
	Standby (maximum)	1097	878	980	1314	924	1239

The above ratings represent the engine performance capabilities guaranteed within plus or minus 3% at the reference conditions equivalent to those specified in ISO 8528/1, ISO 3046/1, BS 5514/1.

Ratings conditions: 25°C air inlet temperature, barometer pressure 100 kPa, relative humidity 30%. Please consult your distributor or the factory for ratings in other ambient conditions. *Note: For full ratings please refer to Perkins Engines Company Limited. All electrical ratings are based on an average alternator efficiency and a power factor of 0.8.* **Fuel specification:** BS 2869 Class A1 + A2 or ASTM D975 No 2D.

Rating definitions

Baseload power: power available for continuous full load operation. No overload is permitted. **Prime power:** Power available for variable load with an average load factor not exceeding 80% of the prime power rating in any 24 hour period. Overload of 10% permitted for 1 hour in every 12 hours operation. **Standby (maximum):** Power available at variable load in the event of a main power network failure up to a maximum of 500 hours per year. No overload is permitted.

Percent of prime power	Fuel consumption at 1800 rpm	
	g/kWh	l/hr
Standby (maximum)	216	249
Prime power	213	224
Baseload power	206	173
75%	206	162
50%	205	108
25%	210	55